

SM 8000



SM-ST 8000



- **Modulador TV BLV Mono / Estéreo**
- **Modulateur TV MABLR Mono / Stéréo**
- **VSB TV Modulator Mono / Stereo**
- **Modulatore TV BLV Mono / Stereo**

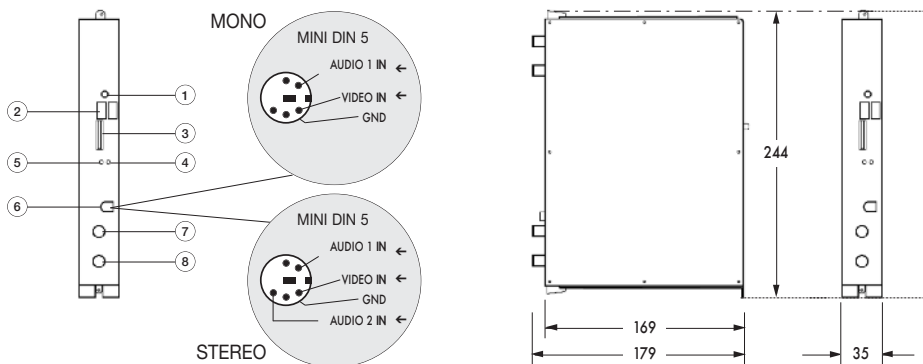

CONTROLES

1. Dirección lógica (MCU 8000)
2. Bus de control
3. Bus de alimentación
4. Led de estado
5. Led de comunicación
6. Entrada Video y Audio
7. Salida canal RF
8. Entrada lazo salida RF

COMMANDES

1. Adresse logique (MCU 8000)
2. Bus de contrôle
3. Bus d'alimentation
4. DEL d'état
5. DEL de communication
6. Entrée vidéo et audio
7. Sortie canal RF
8. Entrée boucle sortie RF

CONTROLS

1. Logical Address (MCU 8000)
2. Control bus
3. Supply bus
4. Status LED
5. Communication LED
6. Video and audio input
7. RF channel output
8. RF output loop input

CONTROLLI

1. Indirizzo logico (MCU 8000)
2. Bus di controllo
3. Bus di alimentazione
4. Led di stato
5. Led di comunicazione
6. Audio e Video input
7. Uscita canale RF COFDM
8. Ingresso anello uscita RF

■ Características principales Caracteristiques principales

Main specifications Caratteristiche principali

E	F	UK	I	SM 8000	SM-ST 8000
Nivel de entrada Audio	Niveau d'entrée Audio	Audio input level	Livello di ingresso Audio	0,5 – 2,5 Vpp	
Nivel de entrada Video	Niveau d'entrée Video	Video input level	Livello di ingresso Video	0,9 – 1,25 Vpp	
Conector de entrada A/V	Connecteur d'entrée A/V	A/V input connector	Connettore di ingresso A/V	Mini DIN 5	
Frecuencia de salida	Fréquence de sortie	Output frequency	Frequenza di uscita	47 – 862 MHz	
Nivel de salida	Niveau de sortie	Output level	Livello di uscita	75 – 90 dBμV	
Espureos en banda	Pureté dans la bande	Spurious in band	Spuri in banda	-56 dBc	
Relacion S/R	Raport S/B	S/N ratio	Relazione S/R	58 dBw	
Estándar de TV	Standard TV	TV standard	TV standard	PAL B/G	
Modos de salida de Audio	Mode de sortie Audio	Audio output mode	Modalità di uscita audio	Mono	Estereo / Dual (AB-BA)
Consumo	Consommation	Consumption	Consumo	6,2 W	7,2 W
Temperatura de funcionamiento	Température de fonctionnement	Operating temperature	Temperatura di lavoro	0 – 45°C	

Housing mounting

Rack mounting

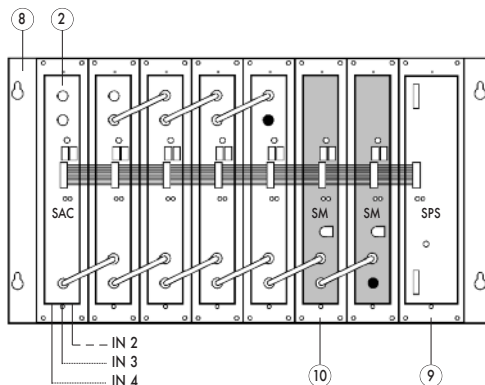
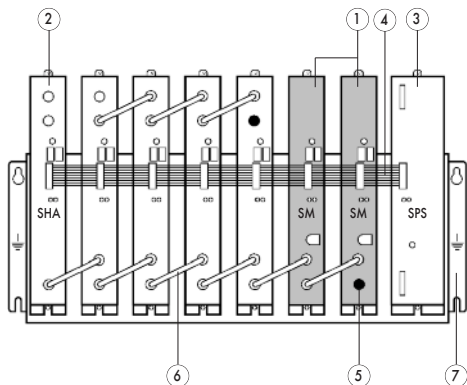

N°	E	F	UK	I	Housing	Rack
1	Modulador TV BLV	Modulateur TV MABLR	VSB TV Modulator	TV Modulatore VSB	19600 (Mono) 19601 (Stereo)	
2	Amplificador SHA/SAC 8000	Amplificateur SHA/SAC 8000	SHA/SAC 8000 amplifier	Amplificatore SHA/SAC 8000	35083 / 35081	
3	Fuente de alimentación SPS	Alimentation SPS	Power supply SPS	Fonte di Alimentazione SPS	68000	
4	Bus de alimentación	Bus d'alimentation	Supply bus	Bus di alimentazione	83807	
5	Carga F, 75 Ω	Charge F, 75 Ω	F load, 75 Ω	Carico F, 75 Ω	84011	
6	Puente RF	Pont RF	RF bridge	Ponte RF	83814	
-	Unidad de control UCF 300	Unité de contrôle UCF 300	UCF 300 control unit	Unità di controllo UCF 300	85115	
7	Bastidor pared	Châssis mural	Wall frame	Telaio a muro	83805	-
8	Bastidor Rack 19" 6U	Châssis Panier 19" 6U	19" 6U rack frame	Telaio Rack 19" 6U	-	83800
9	Carátula adaptación fuente 19"	Façade adaptation alimentation 19"	19" source adaptation front panel	Copertina adattamento fonte 19"	-	83804
10	Carátula adaptación módulo 19"	Façade adaptation module 19"	19" module adaptation front panel	Copertina adattamento modulo 19"	-	83802
-	Cofre con bastidor y aireación	Coffre avec châssis et aération	Housing with frame and fan	Cassetta con telaio e ventilazione	83806	-
-	Unidad de aireación Rack	Unité d'aération Panier	Rack ventilation unit	Unità di ventilazione Rack	-	83801

DESCRIPCIÓN

- Modulador de señales analógicas de video y audio en **Banda Base**, a señal **RF PAL B/G**. En el modelo estéreo, el audio de salida podrá ser estéreo ó dual. El rango de frecuencia RF de salida se encuentra entre los **47 y 862 MHz**.

INSTALACIÓN Y PUESTA EN MARCHA

Las conexiones y desconexiones de los módulos se realizarán con la fuente de alimentación desconectada de la red.



- Conectar la **toma de tierra** del bastidor a la tierra de la instalación de la antena.
- Sujetar los módulos en el bastidor según el **orden** indicado en el **ejemplo de aplicación**, (ver pag 3). Fuente de alimentación a la derecha y amplificador a la izquierda del conjunto.
- Conectar la señal de **video y audio** en Banda Base en el conector **miniDIN 5**.
- Unir las **Salidas de Canal RF** mediante el puente coaxial F-F, y **cargar con 75 Ω** la salida libre del módulo 1, junto a la Fuente de alimentación.
- Conectar el **Bus de Alimentación** BA 807 ref. 83807 entre los módulos y la Fuente de alimentación SPS.
- Conectar la Fuente de alimentación a la **red eléctrica**.

UCF 300: FUNCIONES DE LAS TECLAS

- Las teclas   permiten el desplazamiento vertical por el menú.
 - a) En el **menú de programación** permiten seleccionar la **función** a programar.
 - b) Dentro de una **función** permiten **seleccionar un parámetro**.
 - c) Dentro de un **parámetro programable**, permiten **modificar su valor**.
- Las teclas   permiten el desplazamiento horizontal por el menú de programación, p.ej.:
Función   parámetro   valor.
- La tecla  avanza hacia la derecha.
- La tecla  sale sin modificar el valor: **escape**
- La tecla  valida el dato programado.

UCF 300: INDICACIONES EN EL DISPLAY

- La unidad de control UCF 300 dispone de **dos filas de caracteres** alfanuméricos, el modo de display los datos junto con el **diagrama de programación** de la página 8 nos guían en el proceso:
 - Cuando los caracteres están todos en **mayúsculas** y en la fila **superior** indican que estamos en una de las 4 **funciones**.

- Cuando aparecen **datos en dos filas** del display: estamos viendo el **parámetro a ajustar**.
- La **flecha derecha** indica cómo entrar a **modificar el valor** del parámetro.
- Un **cuadrado parpadeando** indica que podemos **modificar el valor** del parámetro con las teclas   (para validar pulsar la tecla ).

PROGRAMACION con UCF 300

- Conectar la UCF 300 al módulo deseado, después de unos segundos el equipo presenta el modelo del que se trata: SM-ST 8000 ó SM 8000.
- Pulsando la tecla  entramos en las **funciones** del menú principal de programación:
 1. **STANDARD**
 2. **RF OUTPUT**
 3. **VIDEO / AUDIO**
 4. **MEMORY**
- Pulsando las tecla   nos desplazamos por las **funciones**.
- Pulsando la tecla  entramos en los **parámetros** de la función deseada.

1. STANDARD: Estándar de la señal de salida.

1.1. Standard: PAL B/G.

2. RF OUTPUT: Salida de RF

2.1. Out Frequency: Frecuencia de Salida 47 ÷ 862 MHz.

2.2. Out Level: Nivel de salida: 65 ÷ 90 dBµV.

2.3. Out RF: Des/activa la salida de RF.

3. VIDEO/AUDIO: Parámetros asociados con las señales de video y audio.

3.1. Video Test: YES/NO

3.2. Black Video: Video negro: YES/NO

3.3. Audio Level: Volumen: 0 ÷ 12

3.4. Audio Mode: Modos de Audio: Estéreo / Dual AB / Dual BA. (Sólo modelo Estéreo).

3.5. Aud Carrier Lvl: Nivel de la portadora de Audio en RF: 12 / 16 dBc.

4. MEMORY

4.1. Save Configuration: memoriza la programación actual.

- **Memorización automática: después de 30 minutos desde la última tecla pulsada, los datos actuales se memorizarán en el SM 8000 / SM-ST 8000**

4.2. Restore Configuration: permite recuperar la configuración memorizada en el equipo.

4.3. Save Configuration, Device to UCF 300: permite guardar la configuración memorizada con un nombre identificador en una de las 26 memorias de la UCF 300.

4.4. Load Configuration, UCF 300 to Device: recupera los datos de una memoria del UCF 300 para ser clonados en otro equipo SM 8000 / SM-ST 8000.

AJUSTE DE NIVELES DE RF

- **Extraer el puente coaxial** de la Salida de Canal RF del **primer módulo** junto a la Fuente de alimentación.
- **Ajustar** su nivel de salida a **90 dB μ V**.
- **Conectar** de nuevo el puente coaxial de 75 Ω .
- Midiendo en la **salida del Amplificador SHA ó SAC**, regular los niveles de los demás módulos, para lograr **ecualizarlos al nivel del módulo ya regulado**.
- Regular la ganancia del Amplificador de salida, teniendo en cuenta el nivel máximo de su salida y la reducción en función del **número de canales** de la instalación, según la Tabla 1.

Tab. 1

*Nº de canales	2	4	5	6	8	16	24	32	64
Reducción del nivel max. de salida (dB)	0	3	4	5	6	9	11	12	15

* Modulación TV AM

- Cuando existan canales analógicos y digitales los **canales digitales** deben estar al menos **10dB por debajo de los analógicos**.

FUNCIONES DE LOS LEDS

- **Led de estado:**
 - Color **Verde:** OK
 - Color **Amarillo:** Error
 - Color **Rojo:** Equipo averiadod
- **Led de Comunicaciones:** Sólo para programación centralizada con MCU 8000.

DESCRIPTION

- Modulateur analogique pour la vidéo et audio **Bande Base**, à signal **RF PAL B/G**. Dans le modèle audio stéréo la sortie peut être stéréo ou Dual. La gamme de fréquence du sortie RF est compris entre **47 et 862 MHz**.

INSTALLATION ET MISE EN MARCHÉ

- **Les connexions et déconnexions des modules doivent se faire avec l'alimentation débranchée.**

- Relier la **prise de terre** du châssis à la terre de l'installation de l'antenne.
- Fixer les modules sur le châssis dans l'**ordre** indiqué sur l'**exemple d'application** (voir page 3) : alimentation à droite et amplificateur à gauche de l'ensemble.
- Connectez la **vidéo et le audio** signal en bande base sur le connecteur **miniDIN 5**.
- Relier les **Sorties de Canal RF** à l'aide du pont coaxial F-F et **charger avec 75 Ω** la sortie libre du module 1, à côté de l'alimentation.
- Connecter le **Bus d'Alimentation** BA 807 réf. 83807 entre les modules et l'alimentation SPS.
- Brancher l'alimentation sur le **secteur**.

UCF 300: FONCTIONS DES TOUCHES

- Les touches   permettent le déplacement vertical dans le menu.
 - a) Dans le **menu de programmation**, elles servent à choisir la **fonction** à programmer.
 - b) Dans une **fonction**, elles servent à **sélectionner un paramètre**.
 - c) Dans un **paramètre programmable**, elles servent à **modifier sa valeur**.
- Les touches   permettent le déplacement horizontal dans le menu de programmation, ex.:
Fonction   paramètre   valeur.
- La touche  avance vers la droite.
- La touche  quitter sans modifier la valeur : **escape**
- La touche  valide la donnée programmée.

UCF 300: INDICATIONS SUR L'AFFICHEUR

- L'unité de contrôle **UCF 300** dispose de **deux files de caractères** alphanumériques. Le mode d'affichage des données et le **schéma de programmation** de la page 8 nous guident dans le processus :
 - Quand les caractères sont tous en **majuscules** et sur la file **supérieure**, nous sommes dans l'une des **4 fonctions**.
 - Quand les **données apparaissent sur les deux files** de l'écran, nous voyons le **paramètre à régler**.

- La **flèche droite** indique comment **modifier la valeur** du paramètre.
- Un **petit carré clignotant** indique que nous pouvons **modifier la valeur** du paramètre avec les touches   (pour confirmer, presser la touche ).

PROGRAMMATION AVEC UCF 300

- Connecter la UCF 300 au module voulu ; après quelques secondes, l'équipement présente le modèle dont il s'agit : SM-ST 8000 o SM 8000.
- La pression de la touche  donne accès aux **fonctions** du menu principal de programmation :
 1. **STANDARD**
 2. **RF OUTPUT**
 3. **VIDEO / AUDIO**
 4. **MEMORY**
- La pression des touches   nous déplace parmi les **fonctions**.
- La pression la touche  donne accès aux **paramètres** de la fonction recherchée.

1. STANDARD: Standard de la signal de sortie.

1.1. Standard: PAL B/G.

2. RF OUTPUT: Sortie de RF

2.1. Out Frequency: Fréquence de Sortie: 47 ÷ 862 MHz.

2.2. Out Level: Niveau de sortie: 65 ÷ 90 dBµV.

2.3. Out RF: Dés/active la sortie de RF.

3. VIDEO/AUDIO: Paramètres associés aux signaux vidéo et audio

3.1. Video Test: YES/NO

3.2. Black Video: Vidéo noire: YES/NO

3.3. Audio Level: Volume: 0 ÷ 12

3.4. Audio Level: Modes Audio: Stéréo / Dual AB / Dual BA. (Modèle stéréo uniquement).

3.5. Aud Carrier Lvl: Niveau de porteuse RF Audio: 12 / 16 dBc.

4. MEMORY

4.1. Save Configuration: enregistrer la programmation actuelle.

- **Sauvegarde automatique : au bout de 30 minutes sans presser de touche, les données actuelles sont enregistrées sur le SM 8000 / SM-ST 8000.**

4.2. Restore Configuration: permet de récupérer le paramétrage sauvegardé sur l'équipement.

4.3. Save Configuration, Device to UCF 300: permet de conserver le paramétrage sauvegardé avec un identificateur dans l'une des 26 mémoires de l'UCF 300.

4.4. Load Configuration, UCF 300 to Device: récupère les données d'une mémoire de l'UCF 300 pour être clonées sur une autre unité SM 8000 / SM-ST 8000.

■ RÉGLAGE DES NIVEAUX RF

- **Retirer le pont coaxial** de la Sortie de Canal RF du **module 1** à côté de l'alimentation.
- **Régler** le niveau de sortie de ce module sur **90 dB μ V**.
- **Remplacer** le pont coaxial de 75 Ω .
- En mesurant sur la **sortie de l'amplificateur SHA ou SAC**, régler les niveaux des autres modules, pour les **lisser sur le niveau du module 1** déjà réglé.
- Régler le gain de l'amplificateur, en tenant compte du niveau maximum de sa sortie et de la **réduction** en fonction du **nombre de canaux** de l'installation, selon la Table 1.

Tab. 1

*Nombre de canaux	2	4	5	6	8	16	24	32	64
Facteur de réduction sur niveau max. sortie (dB)	0	3	4	5	6	9	11	12	15

* Modulation TV AM

- Lorsqu'il existe des canaux analogiques et numériques, **les canaux numériques** doivent être au minimum **10dB en dessous** des canaux analogiques.

■ FONCTIONS DES DEL

- **DEL d'état :**
 - **Verte:** OK.
 - **Jaune:** Error
 - **Rouge:** équipement en panne
- **DEL de communication :** Seulement pour la programmation centralisée avec MCU 8000.

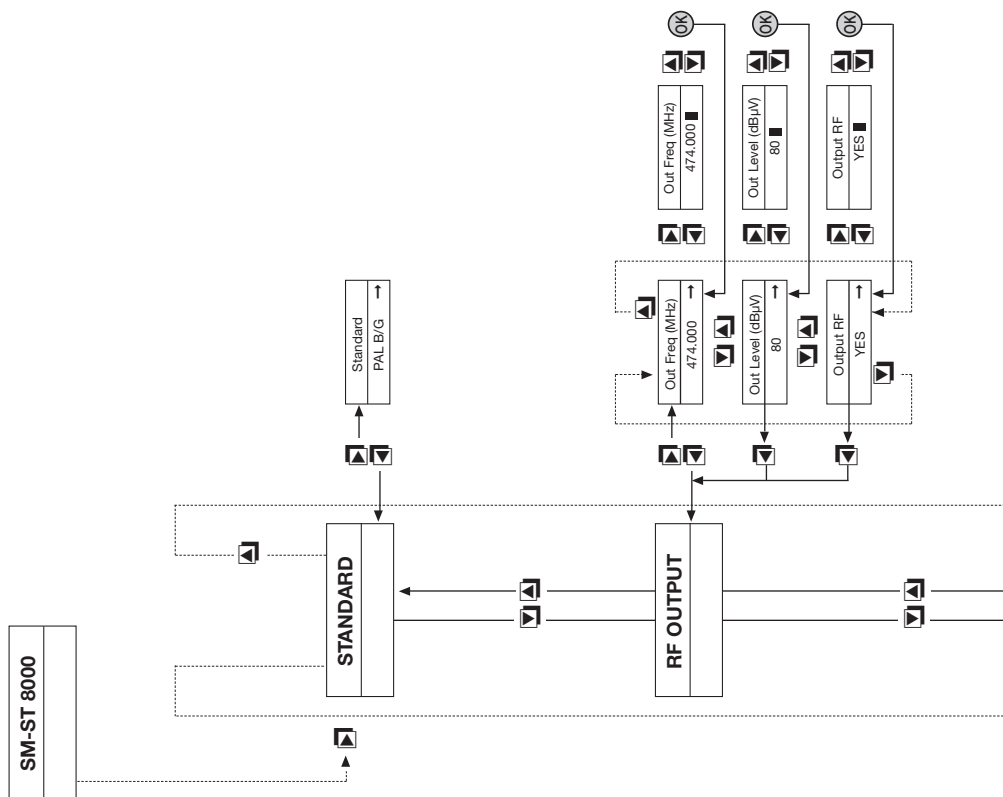

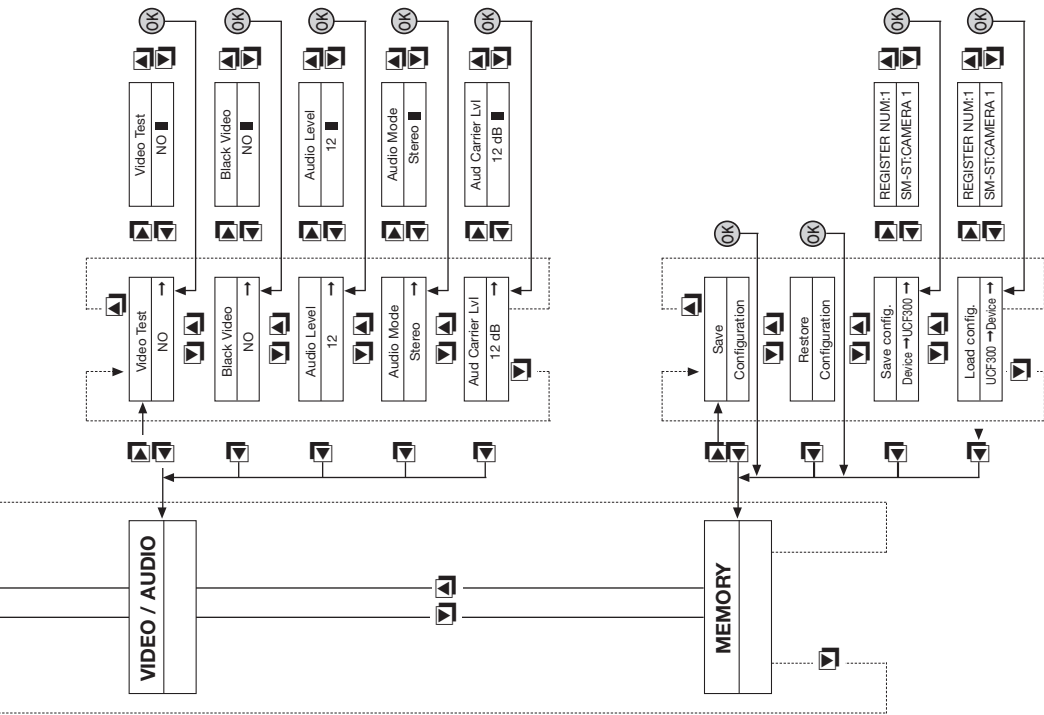

Sólo en el modelo estéreo
 Modèle stéréo uniquement
 Only on the stereo units
 Solo per le unità stereo

DESCRIPTION









- Analog TV modulator for video and audio **Baseband**, to **RF PAL B/G** signal. In the model stereo audio output can be stereo or dual. The frequency range RF output is between **47 and 862 MHz**.

INSTALLATION AND START-UP

- **The power sources must be disconnected from the mains before connecting or disconnecting the module.**



- Connect the **earth connection** of the frame to the earth connection of the antenna installation.
- Fix the modules to the frame in the **order** shown in the **application example** (see page 3), with the power source on the right and the amplifier on the left of the unit.
- Connect the **video and audio** signal Baseband by the connector **minidDIN 5**.
- Join the **RF channel outputs** via the F-F coaxial bridge, and **load** the free output of module 1 **with 75 Ω**, beside the power source.
- Connect the **Supply bus** BA 807 ref. 83807 between the modules and the SPS.
- Connect the power source to the **mains**.

UCF 300: BUTTON FUNCTIONS





- The buttons   are for vertical menu scrolling.
 - a) On the **programming menu** they are for selecting the **function** to be programmed.
 - b) A **parameter can be selected** within a **function**.
 - c) A **parameter setting** can be modified within a **programmable parameter**.
- The   buttons are for horizontal scrolling through the programming menu, e.g.:
Function  parameter  value.
- The  button is for moving right.
- The  button is for exiting without changing the setting: **escape**
- The  button is for validating the data item programmed.

UCF 300: DISPLAY INDICATIONS

- The **UCF 300** control unit has **two rows of alphanumerical** characters. The data display mode and **programming diagram** on page 8 are a guide to this process:
 - If the characters are all **upper case** and on the **upper row**, this indicates that one of the **4 functions** has been entered.
 - If **data appear on two rows** of the display, the **parameter to be adjusted** is being displayed.

- The **right arrow** shows how to enter to **change the parameter setting**.
- A **flashing box** indicates that the **parameter setting can be modified** using the   (press the  button to validate).

PROGRAMMING with UCF 300

- Connect the UCF 300 to the desired module. After a few seconds, the unit will show the model in question: SM-ST 8000 or SM 8000.
- Press the  button to enter the main programming menu **functions**:
 1. **STANDARD**
 2. **RF OUTPUT**
 3. **VIDEO / AUDIO**
 4. **MEMORY**
 - Press the   button to scroll through the **functions**.
 - Press the  button to enter the parameters of the desired **function**.

1. STANDARD: Standard output signal.

1.1. Standard: PAL B/G.

2. RF OUTPUT: RF output

2.1. Out Frequency:

47 ÷ 862 MHz.

2.2. Out Level: 65 ÷ 80 dBµV.

2.3. Out RF: Enables/disables the RF output.

3. VIDEO/AUDIO: Parameters associated with video and audio signals.

3.1. Video Test: YES/NO

3.2. Black Video: YES/NO

3.3. Audio Level: 0 ÷ 12

3.4. Audio Mode: Estéreo / Dual AB / Dual BA. (Only on the stereo units).

3.5. Audio Carrier Level: 12 / 16 dBc.

4. MEMORY

4.1. Save Configuration: Stores current programming.

- **Automatic save: 30 minutes after the last button is pressed, the current data will be stored in the SM 8000 / SM-ST 8000**

4.2. Restore Configuration: Enables the configuration stored in the unit to be recovered.

4.3. Save Configuration, Device to UCF 300:
enables the configuration stored to be saved with an identifying name in one of the 26 memories of the UCF 300.

4.4. Load Configuration, UCF 300 to Device:
recovers the data in one of the UCF 300's memories for cloning on another unit SM 8000 / SM-ST 8000.

RF LEVEL ADJUSTMENT

- **Remove the coaxial bridge** from the RF channel output of **module 1** beside the power source.
- **Adjust** the output level of this module to **90 dB μ V**.
- **Connect** the 75 Ω coaxial bridge again.
- Taking the measurement at the **SHA or SAC amplifier output**, adjust the levels of the other modules so that they are **equalised to the level of module 1**, which has already been adjusted.
- Adjust the amplifier gain, taking into account its maximum output level and the **reduction** according to the **number of the channels** in the installation, as shown in Table 1.

Tab. 1

*Number of channels	2	4	5	6	8	16	24	32	64
Reduction of the maximum output level (dB)	0	3	4	5	6	9	11	12	15

* TV AM modulation

- When there are both analog and digital channels, the **digital channels** must be at least **10 dB lower** than the analog channels.

LED FUNCTIONS

- **Status LED:**
 - **Green:** OK.
 - **Yellow:** Error
 - **Red:** Unit failure
- **Communication LED:** Only for centralized programming with MCU8000.

DESCRIZIONE

- TV modulator analogici per video e audio **Baseband** al segnale **RF PAL B/G**. Nel modello di audio stereo uscita può essere stereo o doppio. La gamma di frequenza RF di uscita è compresa tra **47 e 862 MHz**.

INSTALLAZIONE E AVVIO

- **Le connessioni e sconnessioni dei moduli avvengono con la fonte di alimentazione scollegata dalla rete.**

- Collegare la presa di terra del telaio alla **messa a terra** dell'impianto dell'antenna.
- Fissare i moduli al telaio nell'**ordine** indicato nell'**esempio di applicazione** (v. pag. 3). Fonte di alimentazione a destra e amplificatore a sinistra del gruppo.
- Collegare i segnali **audio e video** in banda base del connettore **miniDIN 5**.
- Unire le **Uscite del canale RF** mediante il ponte coassiale F-F, e **caricare a 75 Ω** l'uscita libera del modulo 1, assieme alla Fonte di alimentazione.
- Collegare il **Bus di alimentazione** BA 807 rif. 83807 fra i moduli e la Fonte di alimentazione SPS.
- Collegare la Fonte di alimentazione alla **rete elettrica**.

UCF 300: FUNZIONI DEI TASTI

- I tasti   permettono di spostarsi verticalmente lungo il menù.
 - a) Nel **menù di programmazione** permettono di selezionare la **funzione** da programmare.
 - b) All'interno di una **funzione** permettono di **selezionare un parametro**.
 - c) All'interno di un **parametro programmabile**, permettono di **modificarne il valore**.
- I tasti   permettono di spostarsi orizzontalmente nel menù di programmazione, ad es.:
Funzione  parametro  valore.
- Il tasto  avanza verso destra.
- Il tasto  esce senza modificare il valore: **escape**
- Il tasto  convalida il dato programmato.

UCF 300: INDICAZIONI SUL DISPLAY

- L'unità di controllo **UCF 300** dispone di **due file di caratteri** alfanumerici; la modalità di visualizzazione dei dati assieme al **diagramma di programmazione** della pagina 8 ci guidano nel processo:
 - Quando i caratteri sono **tutti in maiuscole e nella fila superiore**, indicano che siamo in una delle 5 **funzioni**.
 - Quando compaiono dei **dati su due file** del display: viene visualizzato il **parametro da regolare**.

- La **freccia destra** indica come entrare a **modificare il valore** del parametro.
- Un **quadratino che lampeggia** indica che si può **modificare il valore** del parametro con i tasti   (per convalidare premere il tasto ).

PROGRAMMAZIONE con UCF 300

- Collegare la UCF 300 al modulo desiderato; dopo qualche secondo, l'apparecchio presenta il modello di cui si tratta: SM-ST 8000 o SM 8000.
- Premendo il tasto  si accede alle **funzioni** del menù principale di programmazione:

1. STANDARD

2. RF OUTPUT

3. VIDEO / AUDIO

4. MEMORY

- Premendo i tasti   ci si sposta fra le **funzioni**.
- Premendo il tasto  si entra nei **parametri** della funzione desiderata.

1. STANDARD: Standard uscita del segnale.

1.1. Standard: PAL B/G.

2. RF OUTPUT: Uscita RF

2.1. Out Frequency: Frequenza di uscita:
47 ÷ 862 MHz.

2.2. Out Level: Livello di uscita: 65 ÷ 90 dBµV.

2.3. Out RF: (Dis)attiva l'uscita RF.

3. VIDEO/AUDIO: Parametri associati con i segnali video e audio

3.1. Video Test: YES/NO

3.2. Black Video: YES/NO

3.3. Audio Level: Volumen: 0 ÷ 12

3.4. Audio Mode: Audio modalità: Stereo / Dual AB / Dual BA. (Solo modello stereo).

3.5. Aud Carrier Lvl: Livello della portante audio RF:
12 / 16 dBc.

4. MEMORY

4.1. Save Configuration: Memorizza la programmazione attuale.

- **Memorizzazione automatica: dopo 30 minuti da quando è stato premuto l'ultimo tasto, i dati attuali vengono memorizzati nel SM 8000 / SM-ST 8000**

4.2. Restore Configuration: Permette di recuperare la configurazione memorizzata nel sistema.

4.3. Save Configuration, Device to UCF 300: consente di salvare la configurazione memorizzata con un nome di identificazione in una delle 26 memorie della UCF 300.

4.4. Load Configuration, UCF 300 to Device: recupera i dati di una memoria dell' UCF 300 per clonarli in un altro equipo SM 8000 / SM-ST 8000.

■ REGOLAZIONE DEI LIVELLI RF

- **Estrarre il ponte coassiale** dell'Uscita del canale RF del **modulo 1°** insieme alla Fonte di alimentazione.
- **Regolare il livello di uscita** di tale modulo a **90 dB μ V**.
- **Collegare** di nuovo il **ponte coassiale** da 75 Ω .
- Misurando all'**uscita dell'Amplificatore SHA o SAC**, regolare i livelli degli altri moduli, per **equalizzarli al livello del modulo 1°** già regolato.
- Regolare il coefficiente di amplificazione, tenendo conto del livello massimo dell'uscita dell'Amplificatore e della **riduzione** in funzione del **numero di canali** dell'impianto, come da Tabella 1.

Tab. 1

*N° di canali	2	4	5	6	8	16	24	32	64
Riduzione sul livello d' uscita massimo (dB)	0	3	4	5	6	9	11	12	15

* Modulazione TV AM

- Quando esistono dei canali analogici e digitali, i **canali digitali** devono essere di almeno **10dB al di sotto** di quelli analogici.

■ FUNZIONI DEI LED

- **Led di stato:**
 - Colore **verde**: OK.
 - Colore **giallo**: Errore
 - Colore **rosso**: Sistema guasto
- **Led di comunicazione:** Solo per la programmazione centralizzata con MCU8000.

Norm B,G Europe

CHANNEL	CHANNEL BANDWIDTH		VIDEO (B)	AUDIO (B)	CHANNEL	CHANNEL BANDWIDTH		VIDEO G	AUDIO G	
		MHz	MHz	MHz			MHz	MHz	MHz	
VHF BI	2	47...54	48,25	53,75	UHF	21	470...478	471,25	476,75	
	3	54...61	55,25	60,75		22	478...486	479,25	484,75	
	4	61...68	62,25	67,75		23	486...494	487,25	492,75	
VHF Bs (low)	S1	104...111	105,25	110,75		24	494...502	495,25	500,75	
	S2	111...118	112,25	117,75		25	502...510	503,25	508,75	
	S3	118...125	119,25	124,75		26	510...518	511,25	516,75	
	S4	125...132	126,25	131,75		27	518...526	519,25	524,75	
	S5	132...139	133,25	138,75		28	526...534	527,25	532,75	
	S6	139...146	140,25	145,75		29	534...542	535,25	540,75	
	S7	146...153	147,25	152,75		30	542...550	543,25	548,75	
	S8	153...160	154,25	159,75		31	550...558	551,25	556,75	
	S9	160...167	161,25	166,75		32	558...566	559,25	564,75	
	S10	167...174	168,25	173,75		33	566...574	567,25	572,75	
VHF BIII	5	174...181	175,25	180,75		34	574...582	575,25	580,75	
	6	181...188	182,25	187,75		35	582...590	583,25	588,75	
	7	188...195	189,25	194,75		36	590...598	591,25	596,75	
	8	195...202	196,25	201,75		37	598...606	599,25	604,75	
	9	202...209	203,25	208,75		38	606...614	607,25	612,75	
	10	209...216	210,25	215,75		39	614...622	615,25	620,75	
	11	216...223	217,25	222,75		40	622...630	623,25	628,75	
	12	223...230	224,25	229,75		41	630...638	631,25	636,75	
	VHF Bs (high)	S11	230...237	231,25		236,75	42	638...646	639,25	644,75
		S12	237...244	238,25		243,75	43	646...654	647,25	652,75
		S13	244...251	245,25		250,75	44	654...662	655,25	660,75
		S14	251...258	252,25		257,75	45	662...670	663,25	668,75
S15		258...265	259,25	264,75		46	670...678	671,25	676,75	
S16		265...272	266,25	271,75		47	678...686	679,25	684,75	
S17		272...279	273,25	278,75		48	686...694	687,25	692,75	
S18		279...286	280,25	285,75		49	694...702	695,25	700,75	
S19		286...293	287,25	292,75		50	702...710	703,25	708,75	
S20		293...300	294,25	299,75		51	710...718	711,25	716,75	
VHF Hyperband		S21	302...310	303,25	308,75	52	718...726	719,25	724,75	
		S22	310...318	311,25	316,75	53	726...734	727,25	732,75	
	S23	318...326	319,25	324,75	54	734...742	735,25	740,75		
	S24	326...334	327,25	332,75	55	742...750	743,25	748,75		
	S25	334...342	335,25	340,75	56	750...758	751,25	756,75		
	S26	342...350	343,25	348,75	57	758...766	759,25	764,75		
	S27	350...358	351,25	356,75	58	766...774	767,25	772,75		
	S28	358...366	359,25	364,75	59	774...782	775,25	780,75		
	S29	366...374	367,25	372,75	60	782...790	783,25	788,75		
	S30	374...382	375,25	380,75	61	790...798	791,25	796,75		
	S31	382...390	383,25	388,75	62	798...806	799,25	804,75		
	S32	390...398	391,25	396,75	63	806...814	807,25	812,75		
	S33	398...406	399,25	404,75	64	814...822	815,25	820,75		
	S34	406...414	407,25	412,75	65	822...830	823,25	828,75		
	S35	414...422	415,25	420,75	66	830...838	831,25	836,75		
	S36	422...430	423,25	428,75	67	838...846	839,25	844,75		
	S37	430...438	431,25	436,75	68	846...854	847,25	852,75		
	S38	438...446	439,25	444,75	69	854...862	855,25	860,75		
	S39	446...454	447,25	452,75						
	S40	454...462	455,25	460,75						
	S41	462...470	463,25	468,75						

FAGOR**DECLARACION DE CONFORMIDAD
DECLARATION DE CONFORMITÉ
DECLARATION OF CONFORMITY
DECLARAÇÃO DE CONFORMIDADE**Fabricante/ Fabricant/ Manufacturer/ Fabricante : **FAGOR ELECTRONICA, S.COOP.**Dirección/ Adresse/ Address/ Direção : **Bº San Andrés s/n - P.O. Box 33
20500 MONDRAGON
(Guipúzcoa) Spain**NIF / VAT : **F-20 027975**

Declara bajo su exclusiva responsabilidad la conformidad del producto :
Declare, sous notre responsabilité, la conformité du produit :
Declare under our own responsibility the conformity of the product :
Declara exclusiva responsabilidade a conformidade do producto :

SM 8000

Según los requerimientos de las Directivas del Parlamento Europeo:
Selon les especifications des Directives du Parlement Européen :
According to the specifications of directives of the European Parliament:
Com as especificações da Directivas do Parlamento Europeu:

EMC 89/336/EEC

Para su evaluación se han aplicado las Normas:
Pour l'évaluation ont été appliqués les Normes:
For the evaluation, the following Standards were applied:
Para a avaliação, os seguintes Normas foram aplicados :

UNE - EN 50083-2: 2007Fecha: **Marzo 2010**
Date:Firma: 
Signature: **J.M. Saiz****Jefe Calidad Tratamiento de Señal
Head of Quality Dept., Signal Processing****Fagor Electrónica, S.Coop.**

San Andrés, s/n. P. O. Box 33
E-20500 Mondragón (Spain)
Tel. +34 943 712 526
Fax +34 943 712 893
E-mail: rf.sales@fagorelectronica.es
www.fagorelectronica.com



MONDRAGON

HUMANITY
AT WORKFinance
Industry
People
Knowledge